

CARBURETOR ROUND SLIDE 2 STROKE ENGINES

The motorcycle carburetor is a very touchy device that can cause all kinds of trouble if mishandled or neglected.

Our experience indicates that most of the carburetors sent under warranty don't have anything wrong with them, all it needs to be done is cleaning or adjusting properly.

Frequently factory leave fuel in the carburetors and the gasoline goes bad with time. May be in 3 - 4 weeks can appears the effect known as varnishing, jets and passageways become obstructed when varnishing occurs.

According to this when you get into a carburetor issue, even on new units, such as rough idle, stalling or poor acceleration, the first thing to be done is to take the carburetor apart and clean the jets and all the passageways with carburetor cleaner and then blow compressed air through it. Inspect the jets by holding to light and look through them, you should see an unobstructed round hole.



CARBURETOR

CARBURETOR

- ① Throttle valve spring
- ② Spring catch
- ③ Throttle valve
- ④ Jet needle
- ⑤ Pilot air screw
- ⑥ Throttle stop screw
- ⑦ Needle jet
- ⑧ Main jet
- ⑨ Pilot jet
- ⑩ Float
- ⑪ Float gasket
- ⑫ Drain screw
- ⑬ Needle valve
- ⑭ Float chamber

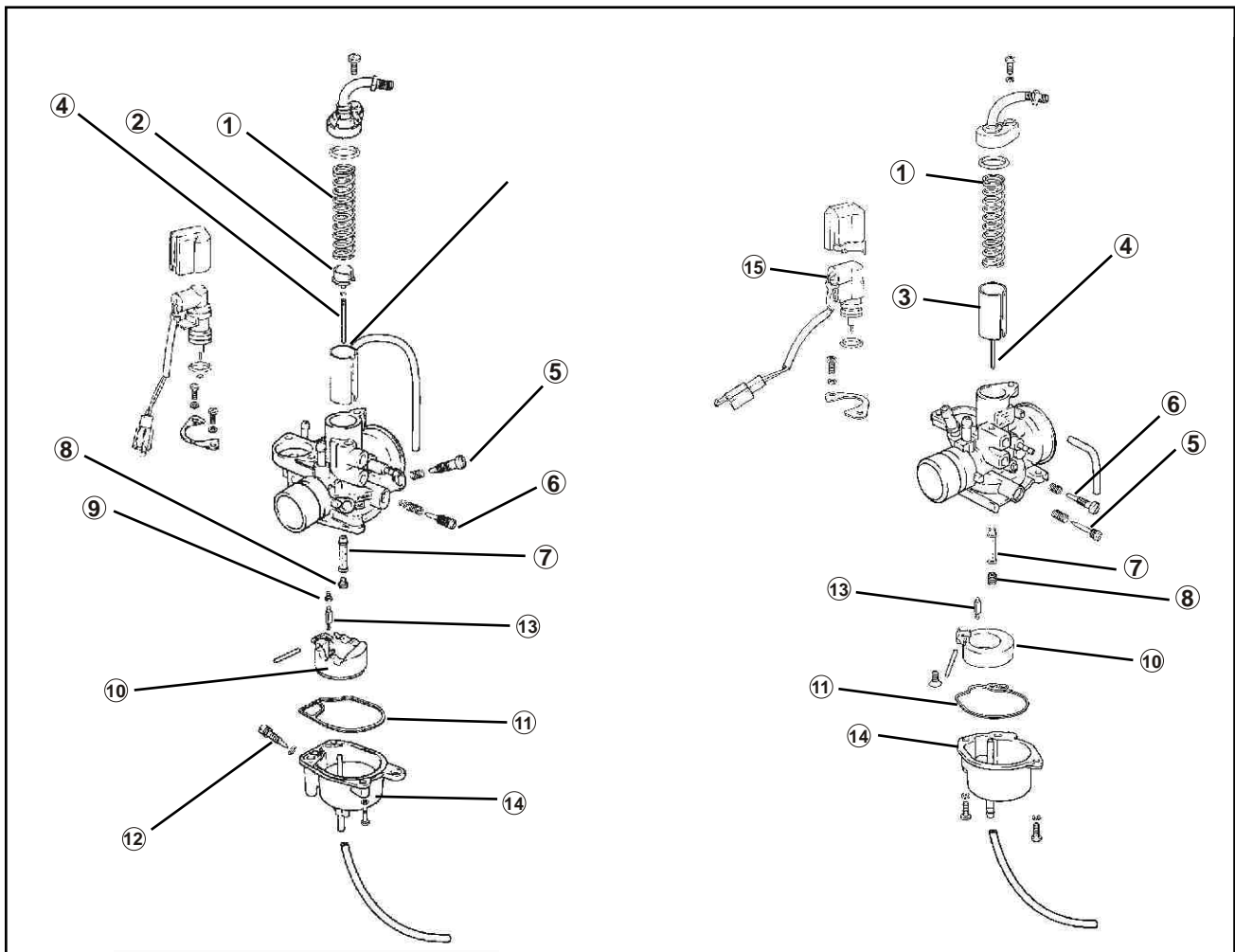

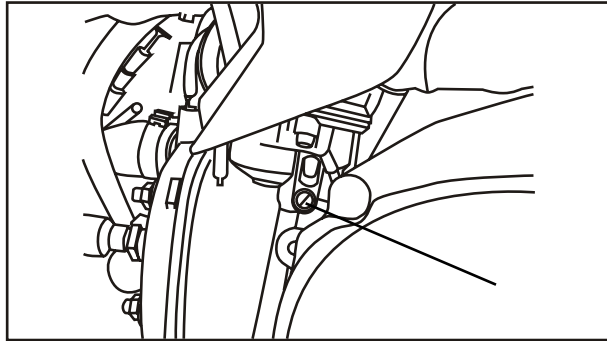

REMOVING THE CARBURETOR

1. Remove:
 - air filter box

2. Drain:
 - fuel (from drain screw ①)

3. Disconnect:
 - autochoke lead coupler ①

 - fuel hose ③
 - vacuum hose ④
 - oil delivery hose ⑤
 - throttle cable (with throttle valve) ⑥
 - clamp (fixing clip) ⑦
4. Remove:
 - carburetor

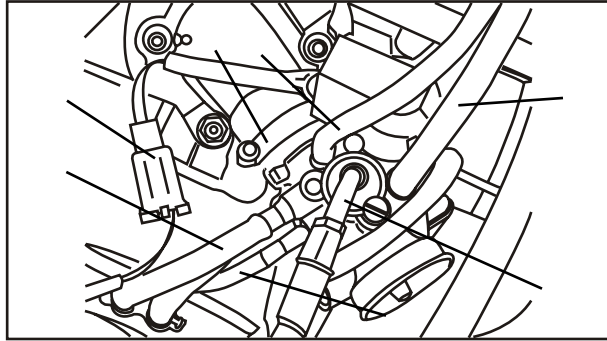

DISASSEMBLING THE CARBURETOR

1. Remove:
 - float chamber ①

2. Remove:
 - float pin ①
 - float ②
 - needle valve ○

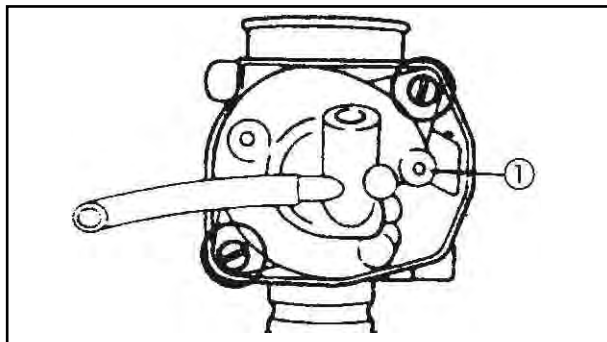

3. Remove:
 - pilot jet 1
 - main jet ②
 - needle jet ③

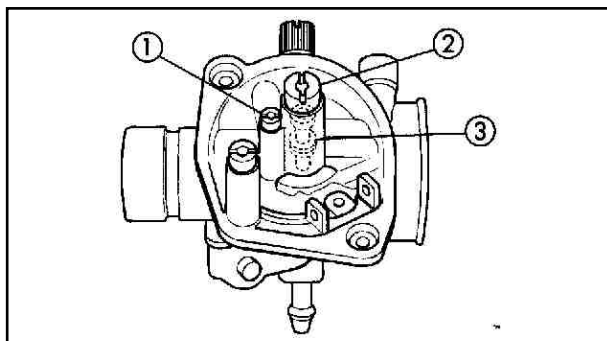
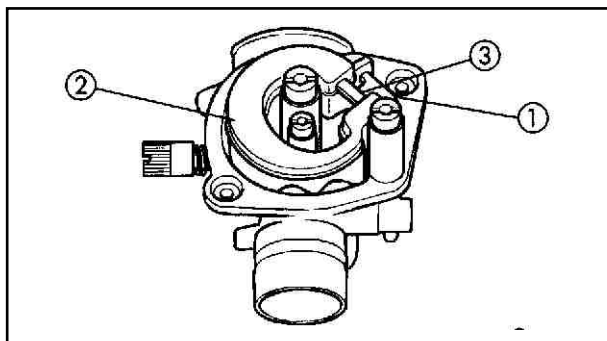

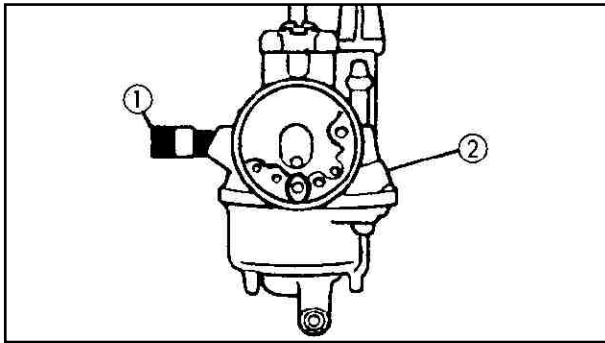

4. Remove:
- throttle stop screw ① (with spring, washer and o-ring)
 - pilot air screw ② (with spring)

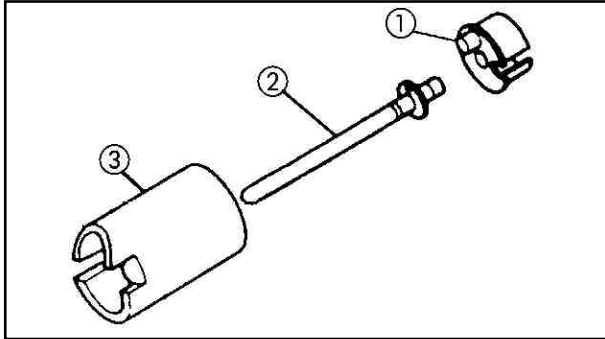

5. Remove:
- spring seat ①
 - jet needle ②
 - throttle valve ③
 - throttle valve spring

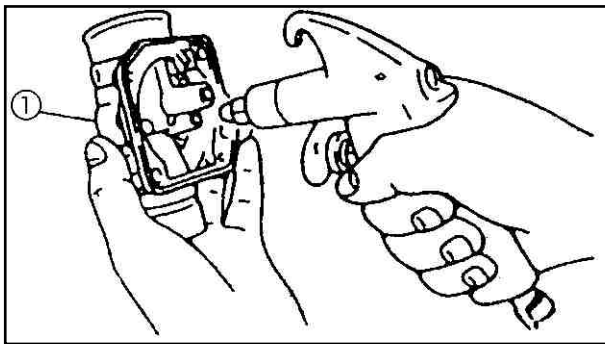

CHECKING THE CARBURETOR

1. Check:
- carburetor body ①
Dirty → Clean

NOTE:

For cleaning, use a petrol based solvent. Clean the pipes and jets with compressed air

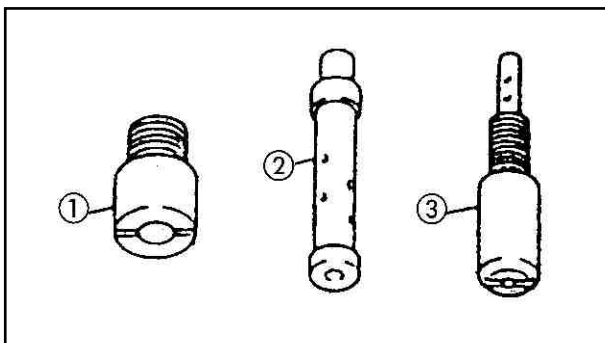

2. Check:
- main jet ①
 - needle jet ②
 - pilot jet ③
Dirty → Clean

3. Check:
- needle valve ①
Wear/Dirty → Clean
 - float ②
Damage → Change
 - gasket Damage → Change

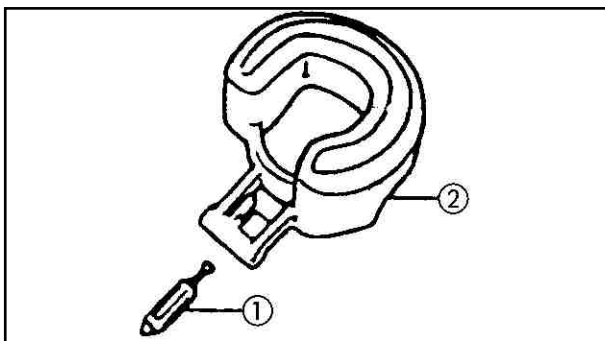

NEEDLE VALVE INSPECTION

If foreign matter is caught between the valve seat and the needle, the fuel will continue flowing and cause it to overflow. If the seat and needle are worn beyond the permissible limits, similar trouble will occur. Conversely, if the needle sticks, the fuel will not float chamber. Clean the float chamber and float parts with fuel. If the needle is worn replace it together with a valve seat. Clean the fuel passage of the mixing chamber with compressed air.

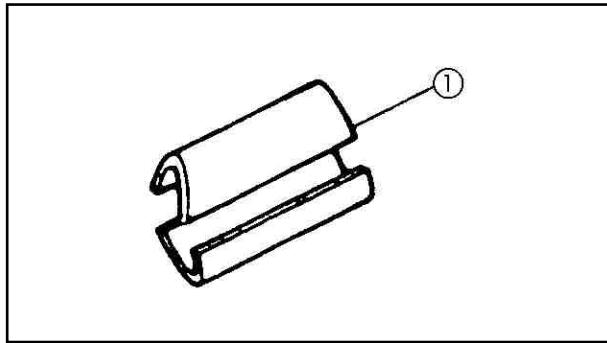

4. Check:
- throttle valve (1)
Wear/Damage → Change

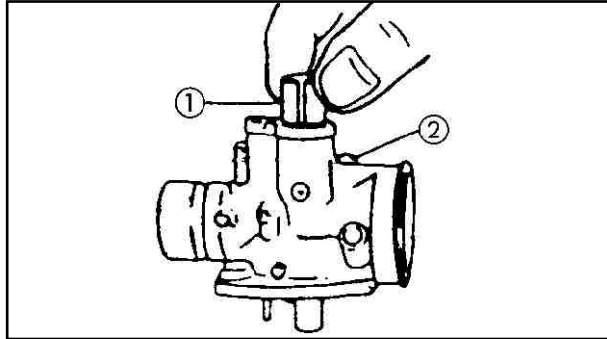

5. Check:
- throttle valve displacement
Irregular movement/Catches → Change
Insert the throttle valve (1) in the body (2) and check its displacement.

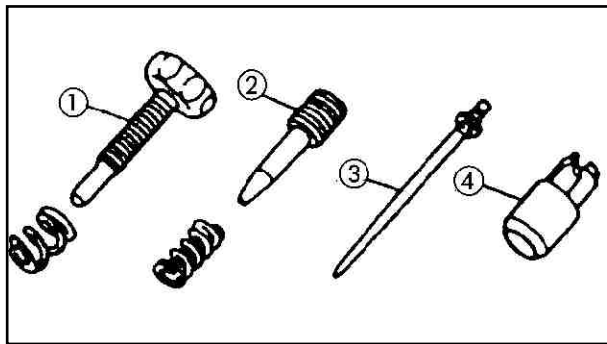

6. Check:
- throttle stop screw (1)
 - pilot air screw (2)
 - jet needle (3)
 - starter plunger (4)
Wear/Damage → Change

CAUTION: _____

When removing the pilot air screw, record the revolutions until tighten completely.

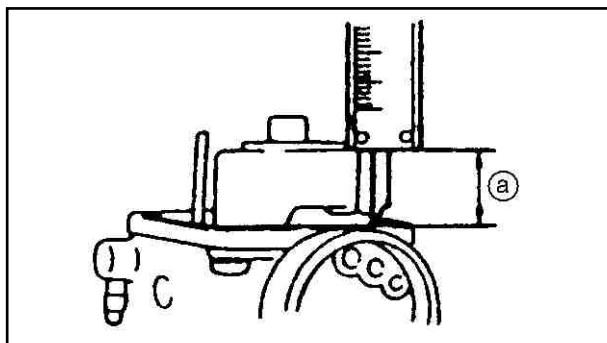

7. Measure:
- Float height a
Outside specifications → Check valve, float and valve seat

	<p>Float height a 15.0 mm ~ 17.0 mm</p>
--	--

Steps for measuring the height of the float:

- Assemble the valve, float and axle on the carburettor body
- Turn the carburettor upside down
- Using a vernier caliper, measure the distance between the plane of the bowl gasket (without the gasket) and the upper part of the float.



NOTE: _____

The arm of the float should be supported on the valve without compressing it.

- If the height of the float is not within the specified limits, inspect the valve and its seat.
- Substitute both parts if any part of them is worn.
- If both are in good condition, replace the float.
- Check the height of the float again.

NOTE: _____

The height of the float is adjusted in the factory. Do not try to modify it under any circumstances.

ASSEMBLING THE CARBURETOR

The assembly of the carburetor is carried out following the reverse procedure to “DISASSEMBLY”. Bear in mind the following points:

CAUTION: _____

✘ Before assembling the carburetor, wash all of the parts in a petroleum-based solvent.

✘ Always use new gaskets.

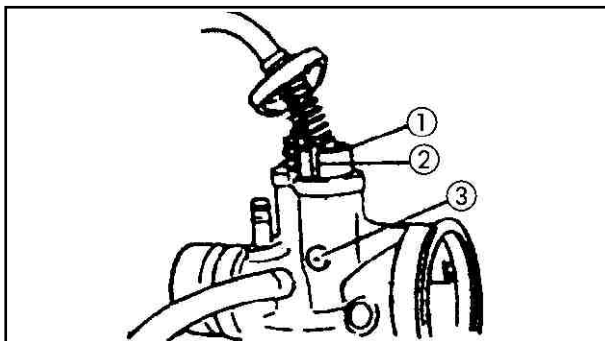
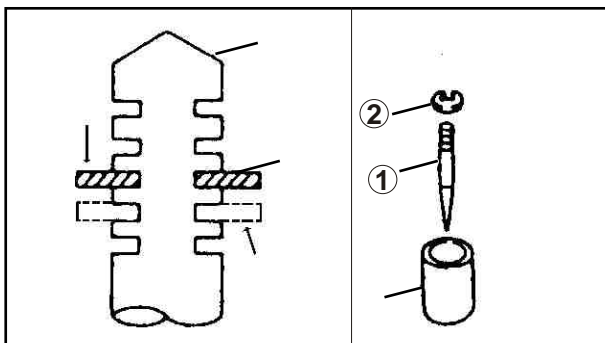

1. Install:
 - jet needle ①
 - clip ②
 - throttle valve ③
 - spring seat
 - spring

2. Install:
 - throttle valve ①

NOTE: _____

Align the groove ② with the carburetor projection ③.



CHECKING THE AUTOCHOKE UNIT

NOTE:

When checking the autochoke unit, the ambient temperature must be lower than 45°C (113°F).

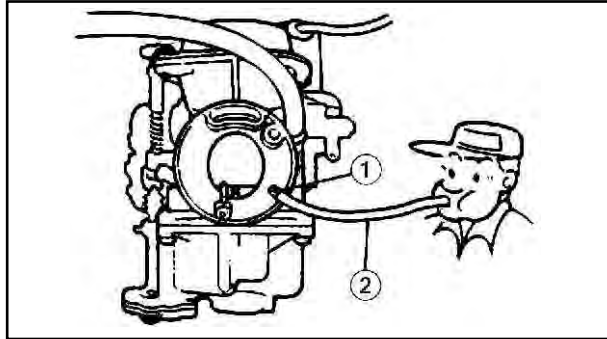

1. Remove:
 - carburetor
2. Check:
 - autochoke unit

- a. Connect a 3.3 mm hose ① to the starter air passage ② and blow into the hose.

NOTE:

When the starter plunger is open, air should come out of the other side of the starter air passage.

Starter plunger opens	Perform step (3)
Starter plunger closes	Replace the autochoke unit.

3. Check:
 - autochoke unit

- a. Connect the autochoke unit leads to a 12.0 V battery for five minutes.

Positive batter lead ①
Negative battery lead ②

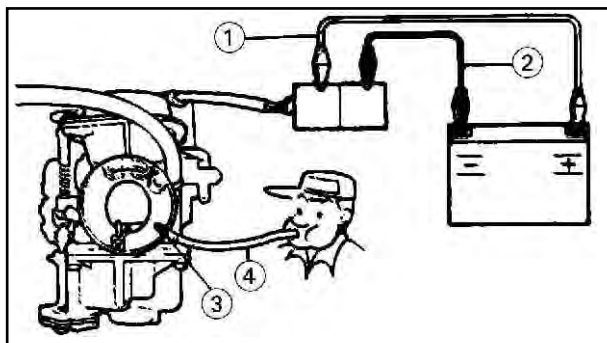

- b. Connect a 3.3 mm hose ③ to the starter air passage ④ and blow into the hose.

Starter plunger opens	Replace the autochoke unit.
Starter plunger closes	Autochoke is OK.

CAUTION:

Do not attempt to disassembly the thermoelement assembly. It is not serviceable.